

Down Angle Marine Transmission

51 to 186 kW
69 to 250 hp

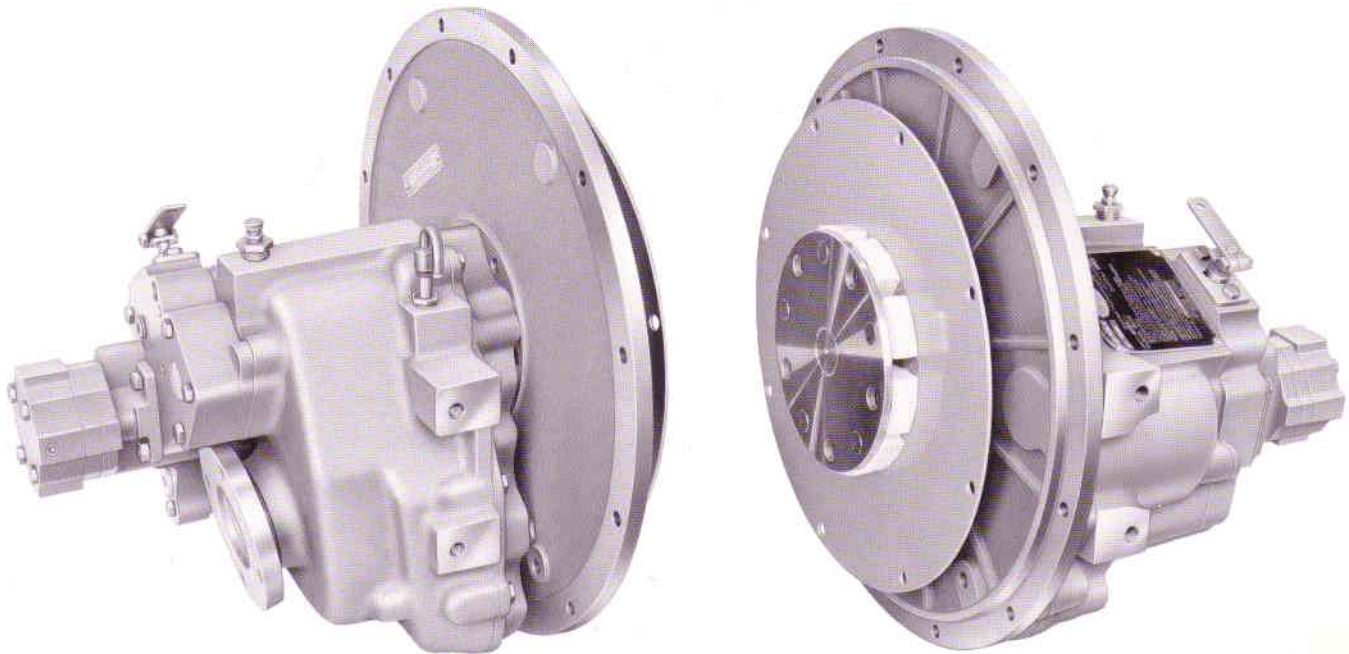

MG-5011A shown with optional SAE #3 pilot flange, 11.5" drive plate and standard oil level gauge

This compact, lightweight, high capacity marine transmission permits the use of higher powered engines that are required for best vessel performance.

The MG-5011A offers conical helical gearing for quieter operation. A

10° down angle provides for near level engine installation. This feature is of particular interest to boat builders and marine architects for optimizing space in planing type hulls.

All ratios are available in one hous-

ing configuration. Identical capacity and ratios in forward or reverse eliminate the need for opposite rotation engines. However, transmissions can be specified for use with left-hand rotation engines.

MODEL ASSY. DWG.	REDUCTION RATIOS :1	INPUT RATINGS - KILOWATTS (HORSEPOWER)						MAX. RATED INPUT SPEED RPM
		CONTINUOUS DUTY		INTERMEDIATE DUTY		PLEASURE CRAFT DUTY		
		2200 RPM	2400 RPM	2500 RPM	2800 RPM	2600 RPM	2800 RPM	
PX9999	1.44, 1.91	51 (69)	56 (75)	107 (144)	120 (161)	173 (232)	186 (250)	4200
	2.39	—	—	—	—	—	—	

Please refer to back cover for service classification definitions.

Please consult Marine Application Department for MG-5011A 2.39:1 Input Ratings.

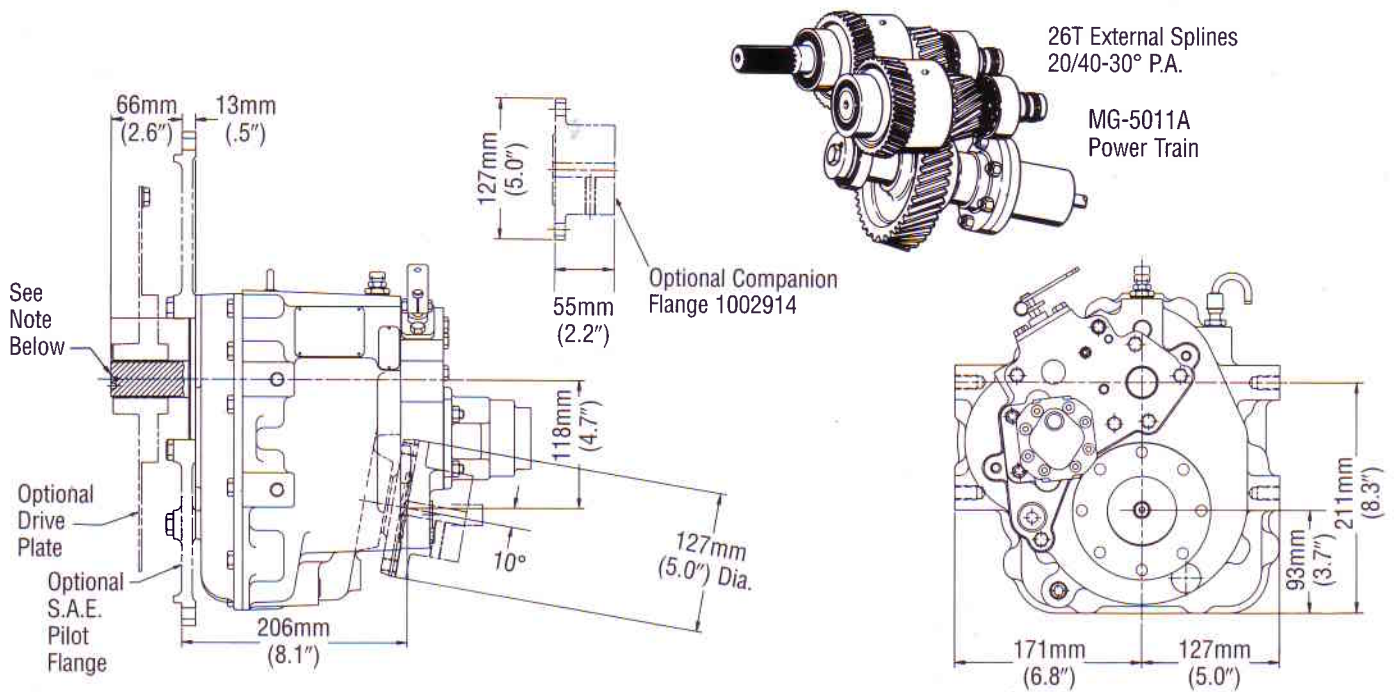

Specifications

- Dry weight – 49 kg (109 lbs.)
- C.I. housing
- Oil strainer standard

Options:

- BW adapter plate (PX9156)
- Std. SAE #3/#4 housing adapter
- #3 caterpillar housing adapter
- SAE 1 1/2" input couplings
 - Spring damper type
 - Rubber type
- Raw/fresh water heat exchangers
- Trolling valve
- Companion flange/bolt set

NOTE: Customer sourced input couplings other than from Twin Disc must have min. axial hub length of 35 mm (1.38").

Specifications subject to change without prior notice in the interest of continual product improvements.

Service Classification Definitions

Continuous Duty

Commonly called "Workboat Duty," these marine transmission applications are expected to operate continuously at full engine governed speed. The propulsion engine power setting must be known and must be within the marine transmission's allowable input rating for continuous daylong or around-the-clock service.

Most displacement hull vessels are powered for Continuous Duty service. However, the actual engine (and marine transmission) power loading depends on:

- a. The propeller used
- b. The vessel's work assignment
- c. The captain's choice of throttle setting during continuous service

Twin Disc recommends that all displacement and semi-displacement hull commercial applications be classed as Continuous Duty usage of the marine transmission.

Examples: Fishing Trawlers, Purse Seiners, Lobster Boats and Crab Boats, Tugs, Tow Boats, Buoy Tenders, Offshore Supply Boats, Ferries, Research Vessels, Ocean Freighters

Intermediate Duty

Pleasure or commercial usage of planing or semi-displacement hull craft can qualify for Intermediate Duty Service Classification if full throttle operation will average only a few hours per day with major portion of usage at partial throttle and total annual usage will be 2000 hours or less.

Examples: Long Range Pleasure Cruisers, Sportfish Charter Boats, Party Fishing Boats, Crew Boats, Harbor and Coastal Patrol Boats, Search and Rescue Boats, Fire Boats

Pleasure Craft

Maximum power capacity is intended only for personal use, planing hull pleasure craft where full engine throttle operation will be less than 5% of total time with balance of time at 87% of full throttle engine rpm or less. Marine transmissions used in long-range pleasure cruisers, sportfish charters or any commercial service should not be selected according to Pleasure Craft Service Classification.

Important Notice: Torsional Vibration
Disregarding propulsion system torsional

compatibility could cause damage to components in the drive train resulting in loss of mobility. At minimum, system incompatibility could result in gear clatter at low speeds.

The responsibility for ensuring that the torsional compatibility of the propulsion system is satisfactory rests with the assembler of the drive and driven equipment.

Torsional vibration analysis can be made by the engine builder, marine survey societies, independent consultants and others. Twin Disc is prepared to assist in finding solutions to potential torsional problems that relate to the marine transmission.

Twin Disc, Incorporated reminds users of these products that their safe operation depends on use in compliance with engineering information provided in this bulletin. Users are also reminded that safe operation depends on proper installation, operation and routine maintenance and inspection under prevailing conditions. It is the responsibility of users (and not Twin Disc, Incorporated) to provide and install guards or safety devices which may be required by recognized safety standards or by the Occupational Safety and Health Act of 1970 and its subsequent provisions.



Twin Disc, Incorporated
Racine, Wisconsin 53403, U.S.A.
414-638-4000/414-638-4482 (fax)
South Africa Singapore Australia Spain Italy
Twin Disc International S.A.
1400 Nivelles, Belgium