

**Down Angle  
Marine Transmission  
235 to 427 kW  
315 to 572 hp**

*From the family of Twin Disc critical performance products*

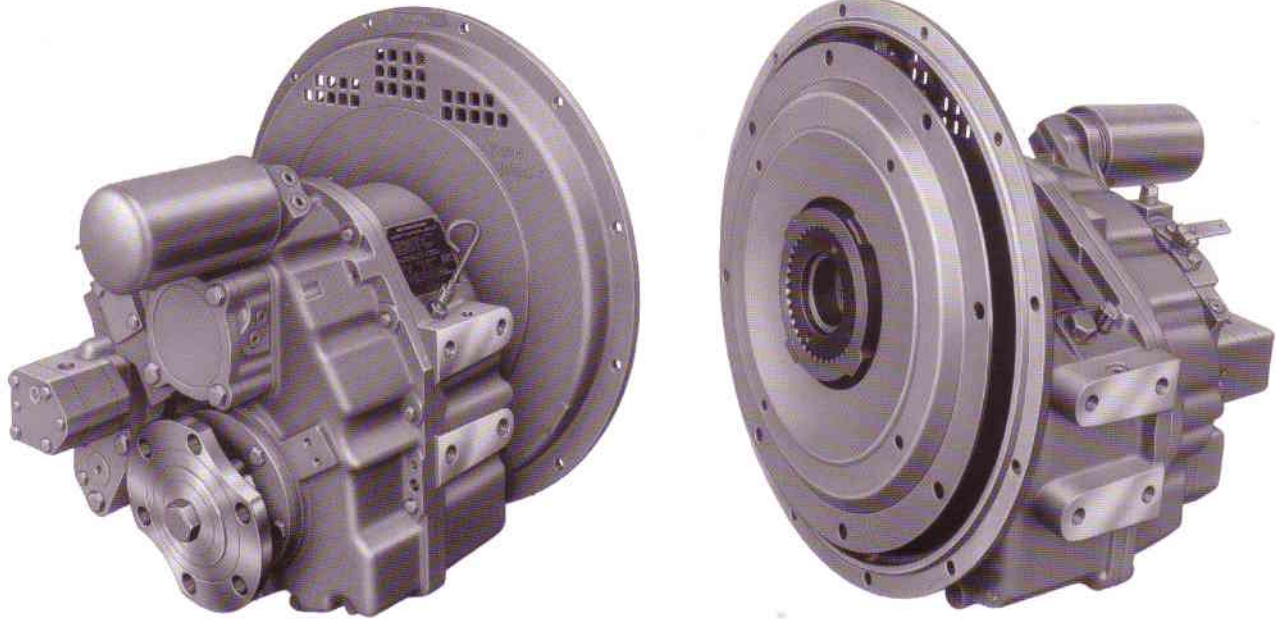

MG-5085A shown with standard input torsional coupling

The MG-5085A down angle model is a high horsepower capacity, compact designed marine transmission utilizing aluminum alloy housing components, single helical gearing, oil-controlled/oil-cooled clutches and a clutch oil fill rate-of-rise valve.

The 7° down angle design provides for near level engine installation and for optimizing engine room space in planing type hulls. This transmission can be operated in either forward or reverse at its full rated horsepower when installed on standard right-hand

rotation marine diesel engines.

There are no external hoses as the MG-5085A transmission case encloses all plumbing except that required for the externally mounted heat exchanger and connections to monitoring devices.

MODEL ASSY. DWG.	REDUCTION RATIOS :1	**INPUT RATINGS - KILOWATTS (HORSEPOWER)		MIN./MAX. RATED INPUT SPEED RPM
		INTERMEDIATE DUTY	PLEASURE CRAFT DUTY	
*PX9360	1.05, 1.22, 1.47, 1.72 2.04 2.43	2100 RPM	2300 RPM	500/3200
		280 (375)	427 (572)	
		280 (375)	410 (550)	
		235 (315)	340 (456)	

\*PX9360A No. 3 housing, starter-over-gear version with SAE 11.5" torsional input coupling. Same ratios as PX9360.

\*\*Please consult Twin Disc for MG-5085A Continuous Duty ratings. Please refer to back cover for service classification definitions.

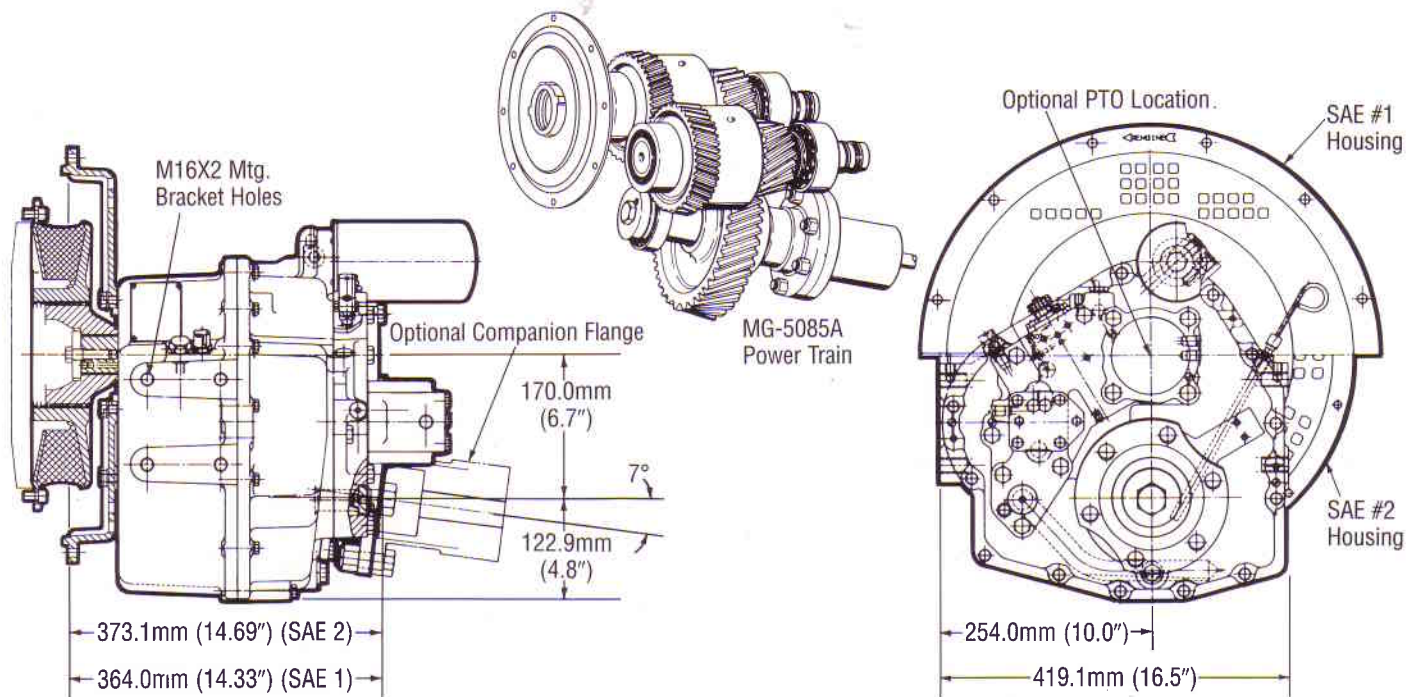

### Specifications

- Dry weight – 123 kg (270 lbs.)
- \*SAE #2 or #1 housings
- Input coupling, torsional type 11 $\frac{1}{2}$ "/14" standard
- Oil strainer/filter standard

\*Please refer to PX9360A for #3 housing, starter-over-gear version

### Options:

- Companion flange/bolt set
- Raw water heat exchanger
- Oil temperature/pressure gauge – mechanical type
- Live SAE 'B' 4-bolt PTO, 37 kW (50 hp) @ 1800 rpm. Turns at engine speed and engine direction of rotation.
- Trolling valve
- Oil pump for use with Left Hand rotation engines
- Mounting brackets
- 12V/24V electric selector valves
- Dual stage input couplings

Specifications subject to change without prior notice in the interest of continual product improvements.

### Service Classification Definitions

#### Intermediate Duty

Pleasure or commercial usage of planing or semi-displacement hull craft can qualify for Intermediate Duty Service Classification if full

throttle operation will average only a few hours per day with major portion of usage at partial throttle and total annual usage will be 2000 hours or less.

*Examples:* Long Range Pleasure Cruisers, Sportfish Charter Boats, Party Fishing Boats, Crew Boats, Harbor and Coastal Patrol Boats, Search and Rescue Boats, Fire Boats

#### Pleasure Craft

Maximum power capacity is intended only for personal use, planing hull pleasure craft where full engine throttle operation will be less than 5% of total time with balance of time at 87% of full throttle engine rpm or less. Marine transmissions used in long-range pleasure cruisers, sportfish charters or any commercial service should not be selected according to Pleasure Craft Service Classification.

#### Important Notice: Torsional Vibration

Disregarding propulsion system torsional compatibility could cause damage to components in the drive train resulting in loss of mobility. At minimum, system incompatibility could result in gear clatter at low speeds.

The responsibility for ensuring that the torsional compatibility of the propulsion system is satisfactory rests with the assembler of the drive and driven equipment.

Torsional vibration analysis can be made by the engine builder, marine survey societies,

independent consultants and others. Twin Disc is prepared to assist in finding solutions to potential torsional problems that relate to the marine transmission.

Twin Disc, Incorporated reminds users of these products that their safe operation depends on use in compliance with engineering information provided in this bulletin. Users are also reminded that safe operation depends on proper installation, operation and routine maintenance and inspection under prevailing conditions. It is the responsibility of users (and not Twin Disc, Incorporated) to provide and install guards or safety devices which may be required by recognized safety standards or by the Occupational Safety and Health Act of 1970 and its subsequent provisions.



Twin Disc, Incorporated  
 Racine, Wisconsin 53403, U.S.A.  
 414-638-4000/414-638-4482 (fax)  
<http://www.twindisc.com>  
 South Africa, Singapore, Australia, Spain, Italy  
 Twin Disc International S.A.  
 1400 Nivelles, Belgium

Bulletin 319-B-85A 8/97  
 ©1997, Twin Disc, Incorporated  
 Printed in United States of America