

Shallow Case Reverse-Reduction Marine Transmission 600 to 969 kW 805 to 1300 hp

Count on Twin Disc when performance is critical

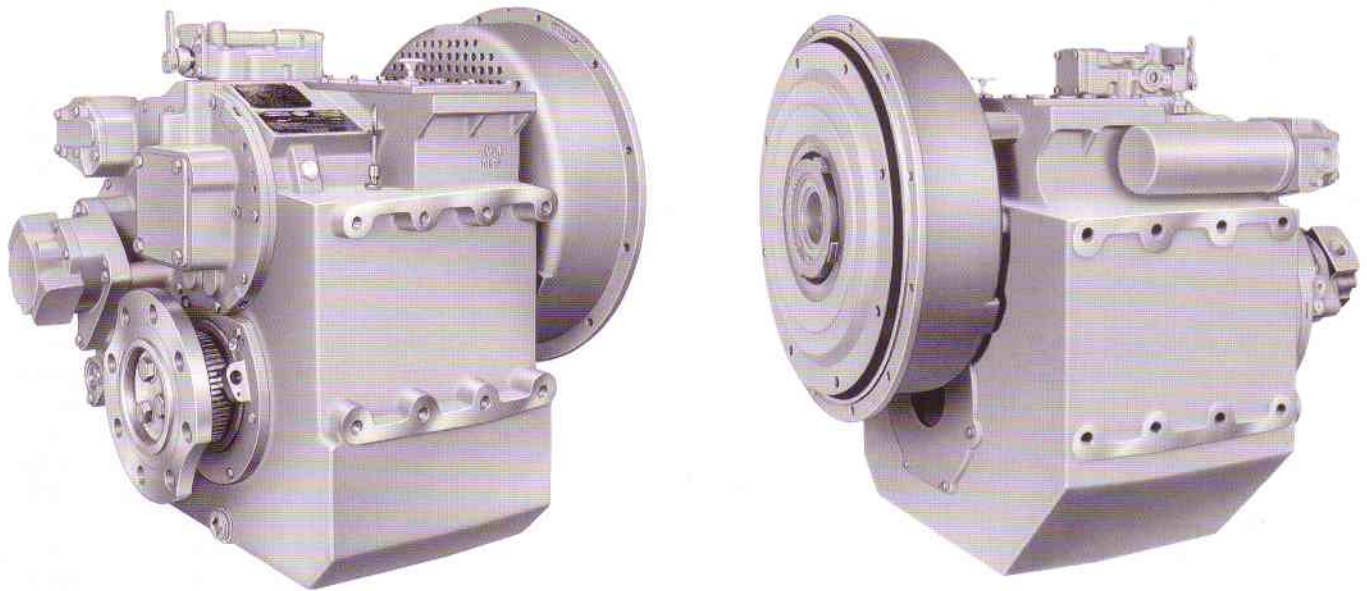

MG-5203SC shown with standard equipment

The lightweight, high horsepower capacity MG-5203SC marine transmission, with excellent reduction-ratio coverage, is designed for propulsion systems with high performance diesel engines to obtain optimum vessel performance.

Like all Twin Disc marine transmissions, the MG-5203SC has been designed and manufactured to give

boat owners many hours of reliable, trouble-free operation.

The ratings/ratios are the same thru forward or thru reverse for ahead propulsion when used with standard right-hand rotation engines.

Single helical ground gearing with oil-controlled/oil-cooled clutches, clutch engagement rate-of-rise feature and a robust light alloy main

housing with conservatively rated anti-friction bearings are utilized in the MG-5203SC.

In-boat maintenance accessibility is another feature of the MG-5203SC. It is not necessary to remove the transmission or disturb alignment for most service functions, provided sufficient space exists aft of the transmission.

MODEL ASSY. DWG.	REDUCTION RATIOS :1	*INPUT RATINGS - KILOWATTS (HORSEPOWER)			MAX. RATED INPUT SPEED AND MIN. ENGINE LOW IDLE SPEED RPM
		CONTINUOUS DUTY	INTERMEDIATE DUTY	PLEASURE CRAFT DUTY	
1016249	1.17, 1.53, 1.76, 2.03, 2.48, 2.92	1800 RPM 600 (805)	2100 RPM 720 (965)	2300 RPM 783 (1050)	2400 max. 450 min.
	3.48	600 (805)	720 (965)	783 (1050)	

Please refer to back cover for service classification definitions.

*Ratings shown for use with standard rotation engines. Consult Twin Disc for ratings for use with non-standard rotation engines.

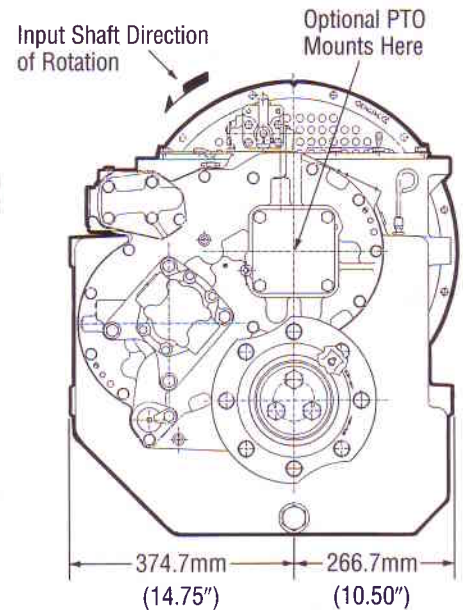
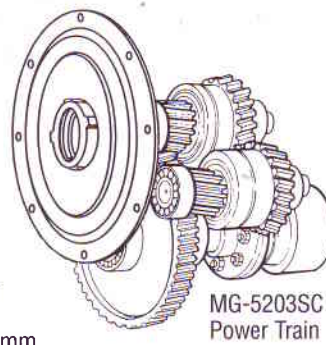
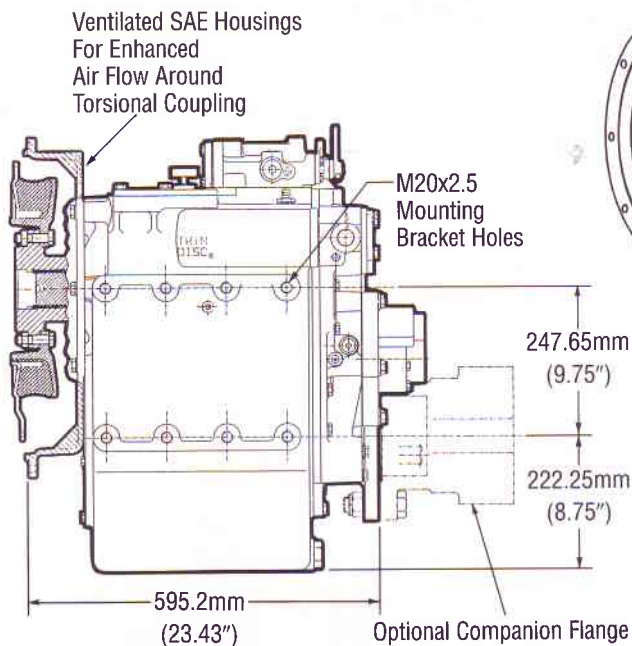

Specifications—MG-5203SC

- Dry weight – 409 kg (900 lbs.) – alloy housing
- SAE #1/SAE #0 housings (alloy)
- 14"/18" torsional input couplings
- Oil strainer/oil filter standard
- Mechanical selector valve standard
- Oil pressure gauge

Options:

- Companion flange/bolt set
- Raw/fresh water heat exchangers
- Mounting brackets
- Trolling valves
- 12V/24V electric selector valves
- PTOs
 - Live SAE 'C' 4-bolt pump 112 kW (150 hp) @ 1800 rpm.
 - With disconnect clutch (hydraulic type) 78 kW (104 hp) @ 1800 rpm.

NOTE: PTOs run at engine speed and in engine direction of rotation.

- Oil temperature gauges with electric high temperature alarm contacts.
 - Metric to NPTF adapter kit
- Specifications subject to change without prior notice in the interest of continual product improvements.

Service Classification Definitions

Continuous Duty

Commonly called "Workboat Duty," these marine transmission applications are expected to operate continuously at full engine governed speed. The propulsion engine power setting must be known and must be within the marine transmission's allowable input rating for continuous daylong or around-the-clock service.

Most displacement hull vessels are pow-

ered for Continuous Duty service. However, the actual engine (and marine transmission) power loading depends on:

- The propeller used
- The vessel's work assignment
- The captain's choice of throttle setting during continuous service

Twin Disc recommends that all displacement and semi-displacement hull commercial applications be classed as Continuous Duty usage of the marine transmission.

Examples: Fishing Trawlers, Purse Seiners, Lobster Boats and Crab Boats, Tugs, Tow Boats, Buoy Tenders, Offshore Supply Boats, Ferries, Research Vessels, Ocean Freighters

Intermediate Duty

Pleasure or Commercial usage of planing or semi-displacement hull craft can qualify for Intermediate Duty Service Classification if full throttle operation will average only a few hours per day with major portion of usage at partial throttle and total annual usage will be 2000 hours or less.

Examples: Long Range Pleasure Cruisers, Sportfish Charter Boats, Party Fishing Boats, Crew Boats, Harbor and Coastal Patrol Boats, Search and Rescue Boats, Fire Boats

Pleasure Craft

Maximum power capacity is intended only for personal use, planing hull pleasure craft where full engine throttle operation will be less than 5% of total time with balance of time at 87% of full throttle engine rpm or less. Marine transmissions used in long-range pleasure cruisers, sportfish charters or any commercial service should not be selected according to Pleasure Craft Service Classification.

Important Notice: Torsional Vibration

Disregarding propulsion system torsional compatibility could cause damage to components in the drive train resulting in loss of mobility. At minimum, system incompatibility could result in gear clatter at low speeds.

The responsibility for ensuring that the torsional compatibility of the propulsion system is satisfactory rests with the assembler of the drive and driven equipment.

Torsional vibration analysis can be made by the engine builder, marine survey societies, independent consultants and others. Twin Disc is prepared to assist in finding solutions to potential torsional problems that relate to the marine transmission.

Twin Disc, Incorporated reminds users of these products that their safe operation depends on use in compliance with engineering information provided in this bulletin. Users are also reminded that safe operation depends on proper installation, operation and routine maintenance and inspection under prevailing conditions. It is the responsibility of users (and not Twin Disc, Incorporated) to provide and install guards or safety devices which may be required by recognized safety standards or by the Occupational Safety and Health Act of 1970 and its subsequent provisions.



Twin Disc, Incorporated
 Racine, Wisconsin 53403, U.S.A.
 414-638-4000/414-638-4482 (fax)
<http://www.twindisc.com>
 South Africa, Singapore, Australia, Spain, Italy
 Twin Disc International S.A.
 1400 Nivelles, Belgium

Bulletin 319-B-203 5M-7/98
 ©1998, Twin Disc, Incorporated
 Printed in United States of America