

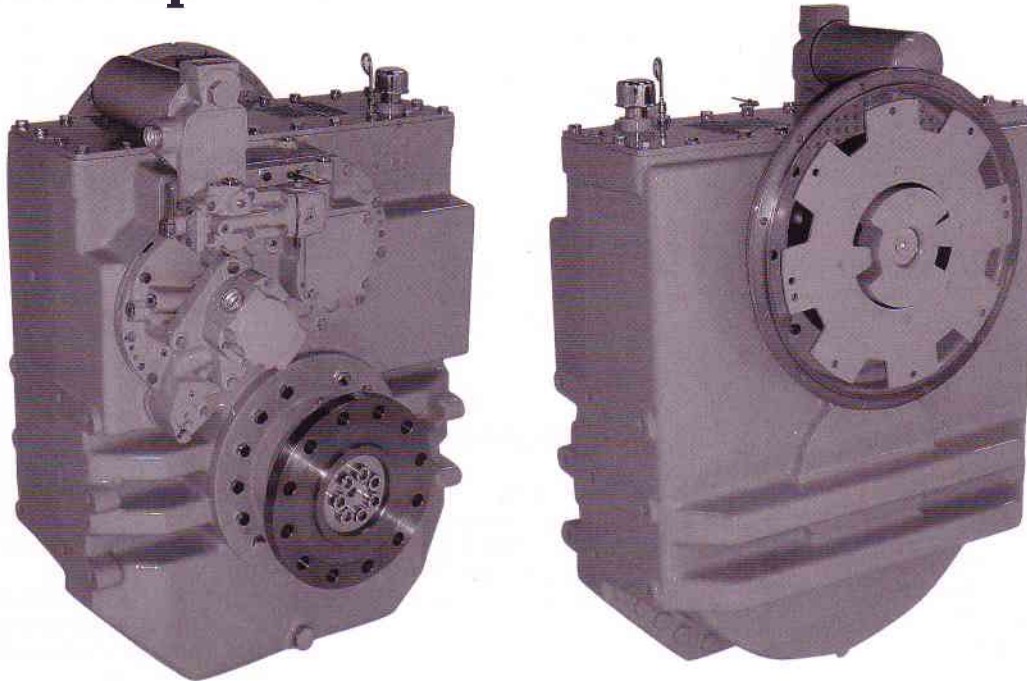

From the Family of Twin Disc Critical Performance Products

Twin Disc
Reverse Reduction
Marine Transmission
600 to 783 kW
805 to 1050 hp



MG-5222DC shown with standard equipment plus optional trolling valve

The MG-5222DC Marine Transmission is designed for use with today's high speed/high output diesel engines in heavy-duty applications.

It is a vertical offset, single reduction marine transmission utilizing carburized, hardened and single helical gearing in a durable one-piece main housing. The fast response primary and secondary

clutches are oil-controlled, oil-cooled and ensure smooth engagement through the Twin Disc rate-of-rise control valve. The MG-5222DC has full rating capability through primary and secondary drive train.

There are no external hoses as the MG-5222DC transmission encloses all plumbing except that required for the

heat exchanger and connections to monitoring devices.

On-board maintenance accessibility is another outstanding feature of the MG-5222DC. It is not necessary to remove the transmission or disturb the foundation for most service functions, provided sufficient space exists aft of the transmission.

MODEL ASSY. DWG.	REDUCTION RATIOS :1	*INPUT RATINGS – KILOWATTS (HORSEPOWER)					MAX. INPUT SPEED AND MIN. ENGINE LOW IDLE SPEED RPM	
		INTERMEDIATE DUTY		MEDIUM DUTY		CONTINUOUS DUTY		
		2100 RPM	2300 RPM	1800 RPM	2100 RPM	1800 RPM		
1020391	4.03, 4.59 5.04, 6.10 6.55, 6.96	720 (965)	783 (1050)	600 (805)	678 (909)	600 (805)	450 MIN. 2500 MAX.	

Please refer to back cover for service classification definitions.
 *Ratings shown for use with standard right hand rotation engines only.

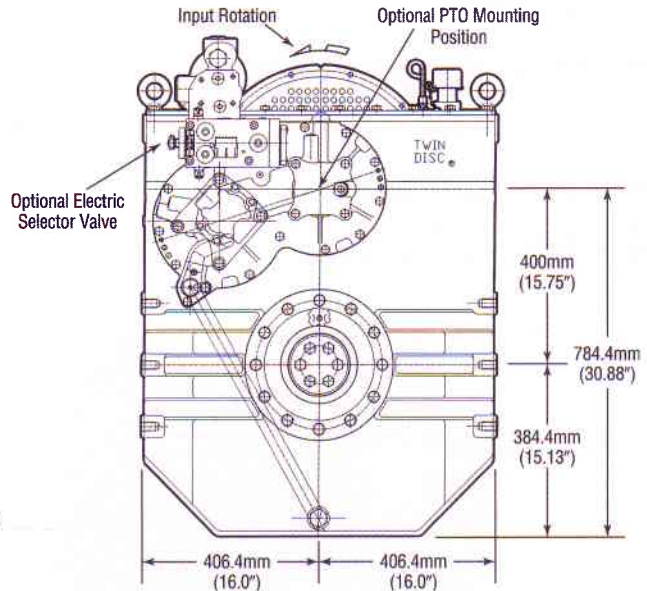
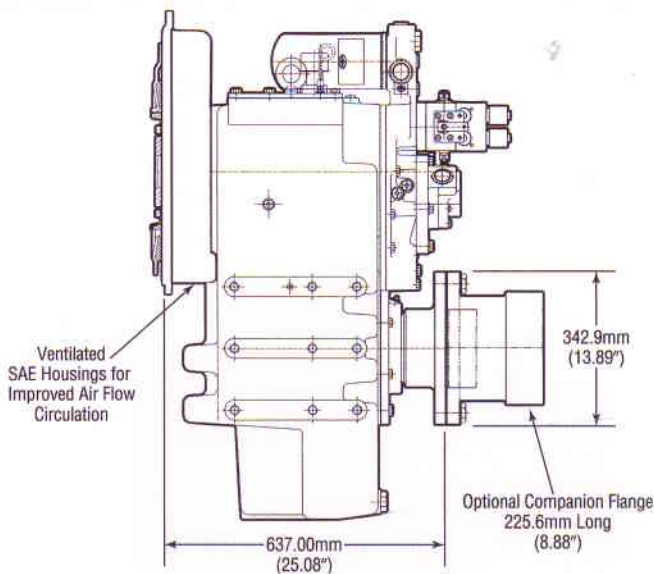

Specifications—MG-522DC:

- Dry weight – 1050 Kg (2313 lbs)
- SAE housings #1 or SAE #0
- Input couplings 14”/18” torsional type - standard
- Oil strainer/filter standard
- Oil pressure gauge standard
- Metric design (except for some power transmitting components)

Options:

- Companion flange/bolt set – Assy. No. 1002312
- Raw or fresh water heat exchangers
- 12V or 24V electric selector valves
- Mounting brackets – 1016428Y
- Electric trailing pump – 1016473
- PTO's: run engine direction/engine speed

Live - Size 32-4, 1017177
Size 38-4, 1017177

With Clutch
Size 32-4, 1017820/B
Size 38-4, 1017820/B

PTO Torque Capacity:
Size 32-4 = 592 N•m (436 lbf-ft)
Size 38-4 = 1187 N•m (875 lbf-ft)

- Free-Standing Arrangement
- Trolling Valves: Electric or Mechanical
- Metric to NPTF Adapter Kit - K1090
- Remote Mounted Oil Filter Kit - K1296
- Oil Temperature Gauge/Switch-B3424
- ABS or other major marine classification societies approval/certificates - consult Twin Disc for details.

Specifications subject to change without prior notice in the interest of continual product improvements.

Service Classification Definitions

Intermediate Duty

Hour usage of up to 2000 hours/year (for models MG-5114 and smaller) and up to 3000 hours/year (for models MG-5145 and larger) with 50% of the operating time at full engine rating.

Typical applications include planing hull vessels such as ferries, fishing boats, some crew boats, and also some displacement hull yachts as well as some bow and stern thruster applications.

Medium Duty

Hour usage of up to 4000 hours/year with up to 80% of operating time at full engine power. This duty classification is for usage where some variations in engine speed/power occur as part of normal vessel operation.

Typical vessels include mid-water trawlers, crew/supply boats, ferries, and some inland water tow boats.

Continuous Duty

For use in continuous operation with little or no variation in engine speed/power settings.

Typical vessels include fishing trawlers, tow/tug boats and ocean going vessels.

Important Notice: Torsional Vibration Disregarding propulsion system torsional compatibility could cause damage to components in the drive train resulting in loss of mobility. At minimum, system incompatibility could result in gear clatter at low speeds.

The responsibility for ensuring that the torsional compatibility of the propulsion system is satisfactory rests with the assembler of the drive and driven equipment.

Torsional vibration analysis can be made by the engine builder, marine survey societies, independent consultants and others. Twin Disc is prepared to assist in finding solutions to potential torsional problems that relate to the marine transmission.

Twin Disc, Incorporated reminds users of these products that their safe operation depends on use in compliance with engineering information provided in this bulletin. User are also reminded that safe operation depends on proper installation, operation and routine maintenance and inspection under prevailing conditions. It is the responsibility of user (and not Twin Disc, Incorporated) to provide and install guards or safety devices which may be required by recognized safety standards or by the Occupational Safety and Health Act of 1970 and its subsequent provision.



Twin Disc, Incorporated
Racine, Wisconsin 53403, U.S.A.
262-638-4000/262-638-4482 (fax)
<http://www.twindisc.com>
Singapore, Australia, Italy
Twin Disc International S.A.
1400 Nivelles, Belgium

Bulletin 319-A-222DC 11/01
©2001, Twin Disc, Incorporated
Printed in United States of America